

Radiation Exposure and Protection in Cardiac Catheterization Laboratories

STEPHEN W. MILLER, MD, and FRANK P. CASTRONOVO, Jr., PhD

Cardiac catheterization with angiography can deliver the greatest dose of x-radiation of any diagnostic medical examination. The physicians and technologists in the angiography room receive low-level scattered radiation over a period of months to decades. Although the radiobiology is complex, the physicians who perform cardiac catheterization should be familiar with the potential genetic and somatic effects of radiation and with the methods to reduce or eliminate x-ray exposure. The aim of

radiation protection criteria is to reduce the risk of cancer death to less than the fatality risk for other occupations regarded as safe. This report is a review of the literature relating to radiation exposure and protection in cardiac catheterization laboratories. Catheterization personnel have control over the time duration of exposure, placement of technologists, shielding, location of equipment and monitoring of dose received.

(Am J Cardiol 1985;55:171-176)

Cineangiography is used daily for the evaluation of patients with heart disease. Cineangiography and fluoroscopy combined make cardiac catheterization the producer of the largest x-ray dose of any examination in diagnostic radiology.^{1,2} The use of x-rays in the catheterization laboratory is generally acceptable because the expected benefits derived from the angiography are considered to outweigh the risks. What are the risks from radiation exposure in the cardiac catheterization laboratory and how can they be reduced?

Sources and Amounts of Radiation Exposure

Numerous studies have documented the radiation exposure to patients and personnel during cardiac catheterization procedures.³⁻¹⁰ The amount of radiation received varies widely among laboratories and depends on the type of equipment used, the operating techniques and length of the procedure, the shielding of the x-ray beam, and the administrative procedures regarding the placement of personnel. The amount of radiation received from a given medical procedure can be compared with that received annually from natural and artificial sources (Table I).

A nationwide survey by the Bureau of Radiological Health estimated that 65% of the people in the United

States were exposed to medical or dental x-rays in 1970.¹¹ Studies have shown that the largest source of exposure of the population to man-made radiation is medical and dental radiologic procedures.^{11,12} The mean dose rates to patients and physicians during cardiac catheterization are listed on Table II. These values are a summary from different types of room installations and procedure times. Most of the patient dose for cardiac procedures is delivered directly by the beam to the thoracic area. Patient-scattered radiation affects mainly the thyroid in adults but also the eye and abdomen in the child. Personnel exposures result from the primary x-ray beam being scattered by tissue in the patient's thorax. The chest, thyroid and eyes receive most of the scattered radiation (Fig. 1).

Genetic and somatic effects of low radiation doses have been the subject of many reviews.¹³⁻¹⁶ Genetic effects are those that affect the germ cells and may be transmitted to the progeny. Somatic effects include malignancies, especially leukemia, cataracts, and developmental abnormalities of children exposed in utero.

The incidence of radiation-induced genetic disorders in humans is uncertain, not only because of the lack of acceptable data but also because of the large number of mutations that are already carried by persons. The incidence of human genetic disorders occurring spontaneously is greater by a factor of 100 compared with that which would additionally occur from parental x-ray exposure.¹² Therefore, the frequency of detectable somatic effects greatly exceeds that resulting from genetic effects.

From the Department of Radiology, Massachusetts General Hospital, Boston, Massachusetts. Manuscript received June 11, 1984; revised manuscript received August 24, 1984, accepted August 27, 1984.

Address for reprints: Stephen W. Miller, MD, Department of Radiology, Massachusetts General Hospital, Boston, Massachusetts 02114.

R506

TABLE III Summary of ALARA Guidelines for Limiting Personnel Exposure to Diagnostic Equipment*

Organ	Maximal Permissible Dose		ALARA	
	Dose (mrem)		10% MPD Level I	30% MPD Level II
	Year	Quarter		
Whole body (including gonads, lens of eye, red bone marrow)	5,000	1,250	125	375
Forearms, hands, feet and ankles	75,000	18,750	1,875	5,625
Skin of whole body	30,000	7,500	750	2,250
Pregnant women or employees < 18 years of age	500	125	125	375
Neck (thyroid)	15,000	3,750	375	937

* No maximal permissible limits are set for patient exposure. ALARA = as low as reasonably achievable; MPD = maximal permissible dose.

hospital radionuclide and x-ray personnel show that the mean annual dose for 1975 was 350 mrem (3.5 mSv); 90% of all personnel, including angiographers, had cumulative annual doses of less than 500 mrem (5 mSv).¹¹ Average exposures for different types of cardiac catheterization procedures are shown in Table IV.⁶

Equipment Considerations

Cineradiographic exposure depends on the radiation dose per frame and the length of the filming time. Published x-ray exposures range from 10 to 120 μ R/frame.²³ At the usual rate of 60 frames/s and 25 μ R/frame, the adult skin exposure rate ranges from 45 to 90 R/min (0.45 to 0.9 Sv/min). A lesser radiation dose per frame would produce a poor-quality image due to statistical fluctuations in the spacial distribution of x-ray photons on the film (quantum mottle). The report of the Inter-Society Commission for Heart Disease Resources²⁴ has recommended 30 to 40 μ R/frame for a 15- to 17-cm field-size image intensifier as a balance between picture quality and minimal radiation exposure to the patient. Included in this report²⁴ are recommendations for beam limitation devices, reduction of scatter by additional shielding around the table, and other shields to protect personnel not required in the room for performance of the procedure. A cardiologist should be aware of the output of the x-ray equipment being used. For example, the microroentgen per frame measurements should be made annually or each time a major component of the x-ray unit is changed. A comprehensive quality control program should be implemented to optimize the performance of other components in the cineradiographic system, such as x-ray generators, image intensifiers, optical systems and film processors.²³

Protective Measures: Time, Distance and Shielding

Specific radiation protection measures that are applicable to all cardiac catheterization laboratories are difficult to prescribe. Certain general radiation protection principles can be adapted for each laboratory. Three variables are the duration of the radiation,

TABLE IV Average Calculated Time and Exposure for Eye and Thyroid During Cardiac Catheterization*

	Time (min)	Exposure mrem (mSv)	
		Eye	Thyroid
Right heart catheterization	15.3	4.9 (0.049)	4.2 (0.042)
Left ventriculography	9.4	3.3 (0.033)	2.8 (0.028)
Right coronary angiography	10.5	9.1 (0.091)	7.7 (0.077)
Left coronary angiography	7.0	6.5 (0.065)	6.2 (0.062)
Total procedure	50.4	31.1 (0.311)	27.6 (0.276)

* Modified from Rueter.⁶

shielding and the distance of personnel from the x-ray source.

About half of the cardiac catheterization exposure comes during fluoroscopy and the remainder during cineangiography.^{4,6,10} The fluoroscopy time can be considerably reduced by using short bursts on the fluoroscope rather than a prolonged, continuous exposure.

The limiting occupational exposure to physicians performing cardiac catheterization is eye exposure. Rueter⁶ estimated that the lens of the eye of the cardiologist receives an average exposure of 20 mR (0.2 mSv) during coronary angiography, left ventriculography and related fluoroscopy.⁶ Figures 1 and 2 show the intensity and distribution of scattered radiation around the angiography table. Based on a recommended maximal dose of 100 mrem (1 mSv)/week to the lens of the eye for occupational workers, a cardiologist should be limited to approximately 5 procedures per week. Rotation of nurses and technicians into nonradiologic areas increases the time interval between exposures and may lessen the likelihood of an individual receiving an excessive exposure.

Newer angiographic equipment with U-arms or C-arms allows compound angled oblique projections. Because the x-ray beam must penetrate an additional thickness of tissue with this equipment, the 40° cranial view may have 2 to 3 times the entrance dose of a stan-

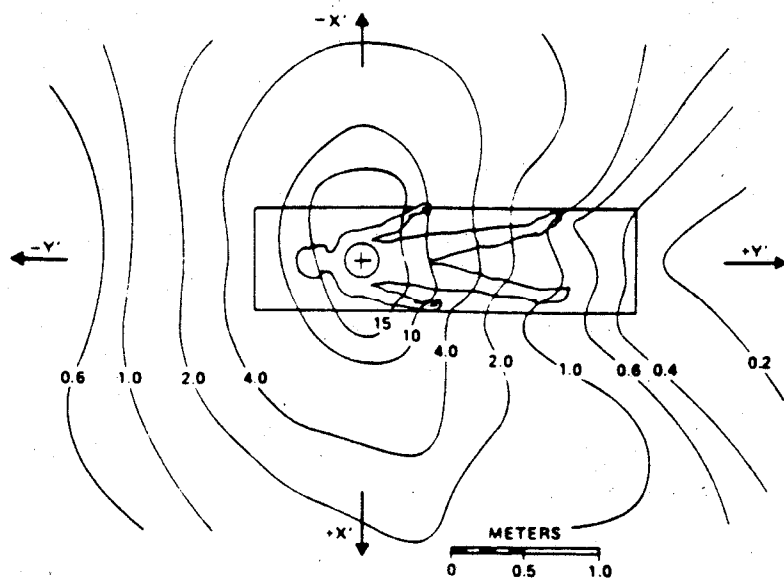

FIGURE 2. Pattern in the horizontal plane of exposure value (milliroentgen/hour) during cardiac catheterization. Typical values of 96 kVp, 10 X 10 cm field and 1.95 R/min tabletop exposure rates were used. (Reprinted by permission of the American Heart Association and from Rueter.⁶)

dard frontal projection.²⁵ The cranial position of the x-ray tube during angulation can result in more scattered radiation to medical personnel (Fig. 3).

The concern about x-ray exposure during pregnancy has been discussed both for the woman as a patient and for the physician performing the catheterization. The American College of Obstetricians and Gynecologists in their guidelines for diagnostic x-ray examinations have suggested that attempts to schedule studies of women of reproductive age in relation to menstrual cycle are of little value, and there is no measurable advantage for scheduling examinations at any particular time during the normal menstrual cycle.²⁶ An estimation of a conceptus dose in pregnant woman radiologists has suggested that a woman cardiologist would receive less than 1 mrem (0.01 mSv) of gonadal dose per examination and therefore could perform 5 catheterizations per day and still receive less than the maximal permissible conceptus dose of 500 mrem (5 mSv)/gestation.²⁷

Because radiation decreases as the square of the distance from the source, all personnel who are not needed in the room should be located elsewhere. For instance, the electrophysiologic data collection can be performed from a remote location rather than beside the fluoroscopy table. Nurses and technicians who remain in the room should be as far away as practical from the x-ray tube. Although coronary angiography is traditionally performed by using a hand-injection technique, all angiographic procedures can be accomplished with a power injector, thereby allowing all personnel to leave the room during the cineangiography.

Lead shielding is the third method to reduce personnel exposure. Collimation of the x-ray beam reduces secondary scatter to the patient and physician and also improves image quality. Movable shields or drapes are available for most of the current angiographic units. Side drapes between the patient and operator reduce scatter from the patient that would otherwise be received by the cardiologist. Specially designed shields have been developed for C-arm imaging systems, which

are used for compound hemiaxial projections.²⁸ Because the thyroid and eyes receive most of the scattered radiation, thyroid shields and leaded eyeglasses may be used by a full-time angiographer.²⁹ These protective devices are recommended by the ALARA guidelines for those who perform many studies. Multilayered lead aprons with the equivalent of 0.5 mm of lead are available in multiple configurations. The selection of an apron will depend on the task of the laboratory personnel; technologists with their back to the patient should wear a full wraparound apron. If this type of apron is too heavy, a 2-piece apron is available consisting of a jacket and a skirt.

Protection of the patient during cardiac catheterization consists mainly of shielding the gonadal area. Once the catheters have been introduced from a femoral arterial site, both male and female patients should have the reproductive organ dose decreased by placing a lead apron beneath the pelvis for an under table tube location. Gonadal shielding is of particular importance in pediatric patients because the primary beam centers on the thorax is much closer to the gonads than in the adult.

Conclusion

There is no dose of radiation that can be considered safe or harmless. Because diagnostic x-rays are the greatest single source of man-made radiation, the physician must assess judiciously the benefits and risk of medical x-rays. Exposure of patients with almost certain pathologic findings to x-ray radiation is justified to produce a diagnostic image if danger of the present disease outweighs the small probability of future hazard from radiation. Examples are the patient who is to undergo coronary artery surgery or the cyanotic infant who needs an immediate and accurate anatomic diagnosis. However, in a longer time frame, the physician, nurse and technologists working in the cardiac catheterization laboratory are subjected to a very low dose of scattered radiation, which is absorbed over a period of months to years to decades. Personnel dose-reduction techniques

- protection. *Radiat Res* 1977;71:51-74.
14. Webster EW. Garland Lecture. On the question of cancer induction by small x-ray doses. *AJR* 1981;137:647-666.
 15. Bross IDJ, Ball M, Falen S. A dosage response curve for the 1 rad range: adult risks from diagnostic radiation. *Am J Public Health* 1979;69:130-136.
 16. National Council on Radiation Protection and Measurements. Influence of dose and its distribution in time and dose-response relationships for low-LET radiations. NCRP report no 64. Washington DC:1980.
 17. Smith PG, Doll R. Mortality from cancer and all causes among British radiologists. *Br J Radiol* 1981;54:187-194.
 18. Merriam GR, Focht EF. A clinical study of radiation cataracts and the relationship to dose. *AJR* 1957;77:759-785.
 19. Bateman JL, Bond VP. Lens opacification in mice exposed to fast neutrons. *Radiat Res* 1967; suppl 7:239-249.
 20. National Council on Radiation Protection. Basic radiation protection criteria. Report No. 39, Washington DC: 1971.
 21. National Council on Radiation Protection. Operational radiation safety program. Report No. 59, Washington DC: 1978.
 22. National Council on Radiation Protection. Instrumentation and monitoring methods for radiation protection. Report No. 57, Washington DC: 1978.
 23. Webster EW. Quality assurance in cineradiographic systems. In: Waggner RG, Wilson CR, eds. Quality Assurance in Diagnostic Radiology. Medical Physics Monograph No. 4. American Institute of Physics 1980: 49-69.
 24. Friesinger GC, Adams DF, Bourassa MG, Carlsson E, Elliott LP, Gessar IH, Greenspan RH, Grossman W, Judkins MP, Kennedy JW, Sheldon W. Optimal resources for examination of the heart and lungs: cardiac catheterization and radiographic facilities. Examination of the chest and card vascular system study group. *Circulation* 1983;68:893A-930A.
 25. Fellows KE, Keane JF, Freed MD. Angled views in cineangiocardiology of congenital heart disease. *Circulation* 1977;56:485-490.
 26. Guidelines for diagnostic x-ray examination of the fertile woman: statement of policy in the Executive Board of the American College of Obstetrics and Gynecologists. 1977. Quoted in Ref. 25:926A.
 27. Wagner LK, Hayman LA. Pregnancy and Women Radiologists. *Radiol* 1982;145:559-562.
 28. Gertz EW, Wisniewski JA, Gould RG, Akin JR. Improved radiation protection for physicians performing cardiac catheterization. *Am J Cardiol* 1975;35:1283-1286.
 29. Richman AH, Chan B, Katz M. Effectiveness of lead lenses in reducing radiation exposure. *Radiology* 1976;121:357-359.
 30. International Commission on Radiological Protection. Recommendations of the ICRP on Radiological Protection. ICRP Publ. 26. Oxford: Pergamon Press, 1977.
 31. International Commission on Radiological Protection. Problems involved in developing and index of harm. ICRP Publ. 27. Oxford: Pergamon Press, 1977.